

# Synthesis of a Class of Microwave Filters\*

HAROLD SEIDEL†

**Summary**—This paper deals with the development of a new model for a class of microwave filters. With this model one can reproduce and systematize from a general viewpoint results now in the literature. Its most prominent feature, however, is that the use of the model permits the development of a synthesis procedure for the wide-band filter. From this single model a wide variety of structural realizations are readily obtained. Designs employing this model, and the appropriate synthesis, show significant improvement of desired characteristics over conventional designs. The general multiple quarter wave matching transformer problem is also discussed.

## I. INTRODUCTION

THE PURPOSE of this paper is to unify various representations and designs of a class of reactive filters, of which the quarter wave coupled cavity filter<sup>1</sup> is representative. Herein structures are sought that have symmetric insertion loss characteristics about a given frequency and are characterized by an even polynomial loss function in terms of an appropriate frequency sensitive variable. Among others of possible interest included in this class are Tchebycheff and maximally flat responses. The form of the filter representation also leads simply to the design of multiple quarter wave matching transformers. This design is included in one section of this paper.

The building block chosen in a pair of equal transformers, as shown in Fig. 1, separated by a transmission

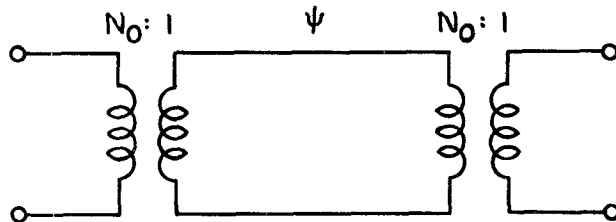

Fig. 1—Transformer representation of a resonant cavity.

line of electrical length  $\psi$  and having a relative characteristic impedance of value unity. When  $\psi$  takes on a quarter wavelength value, this network transmits without reflection and behaves in the manner of a resonant cavity. Since the cavity has been somewhat ambiguously represented in the literature, Fig. 1 will be taken as a defining representation to within the appendage of a quarter wavelength transmission line.

This representation has two features of interest: 1) the transmission line length at resonance is not a

function of the transformer value, and, 2) direct cascades of resonant cavities of the form of Fig. 1 lead to polynomial insertion losses in the variable  $\cos \psi$ . These features permit a simple representation of a structural realization without the necessity of taking into account small phase corrections associated with the cavity loading or the interaction of adjacent cavities.<sup>2</sup> A symmetric array of cavity  $Q$  values leads to even polynomial insertion losses covering the class of present interest. These cavity loadings, or  $Q$  values, will be discussed more explicitly in the text.

The class of filters to be discussed is roughly similar to that of ladder networks in lumped element theory and, indeed, it will be shown that the ladder is the limiting microwave filter representation in the narrow band region of design. All the structures to be examined are formed from cascades of simple elements and are minimum phase networks. The multimode or bridge type structures<sup>3-5</sup> are excluded because they are not of this category. The filter is analyzed through the use of a transfer matrix<sup>6</sup> ( $ABCD$  matrix), with a minor modification of the current flow convention.

The rigorous synthesis procedure described for arbitrary bandwidth filters extends the Darlington procedure for lumped element networks to the case of distributed line elements. A method of factoring is used in a fashion similar to that for lumped element synthesis, but with appropriate radical quantities involved in the factors characterizing the distribution effects.

The following section presents a review of certain aspects of four-pole theory and transformer equivalents. Section III is concerned with filter equivalents. Section IV extends the prior section to show its relation to quarter wave matching transformer design. Finally, section V covers the synthesis and realization of a general filter design.

## II. REACTIVE FOUR-POLE EQUIVALENTS

### A. Transfer Matrix Properties

The transfer matrix is defined by means of the conventions indicated in Fig. 2.

$$\begin{pmatrix} E_1 \\ I_1 \end{pmatrix} = \begin{pmatrix} A & i\beta \\ i\gamma & D \end{pmatrix} \begin{pmatrix} E_2 \\ I_2 \end{pmatrix}. \quad (1)$$

<sup>2</sup> W. W. Mumford, "Maximally flat filters in waveguide," *Bell Sys. Tech. J.*, vol. 27, pp. 684-713; October, 1948.

<sup>3</sup> J. R. Whinnery, "Design of Microwave Filters," Symposium on Modern Network Synthesis, Brooklyn Polytech. Inst., Brooklyn, N. Y., pp. 293-301; April, 1952.

<sup>4</sup> S. B. Cohn, "Analysis of a wide-band waveguide filter," *Proc. IRE*, vol. 37, pp. 651-656; June, 1949.

<sup>5</sup> S. B. Cohn, "Design relations for the wide-band waveguide filter," *Proc. IRE*, vol. 38, pp. 799-803; July, 1950.

<sup>6</sup> E. A. Guillemin, "Communication Networks, Vol. II," John Wiley and Sons, Inc., London, Eng., pp. 144-152; 1935.

\* Manuscript received by the PGM-TT, June 28, 1956. This paper is a portion of a dissertation submitted in partial fulfillment of the degree of Doctor of electrical engineering at the Polytech. Inst. of Brooklyn, Brooklyn, N. Y.; May, 1954.

† Bell Telephone Labs., Inc., Murray Hill, N. J.

<sup>1</sup> R. M. Fano and A. W. Lawson, "Microwave filters using quarter-wave couplings," *Proc. IRE*, vol. 35, pp. 1318-1324; November, 1947.

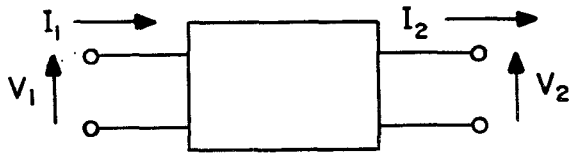

Fig. 2—Four-pole conventions.

$A$ ,  $D$ ,  $\beta$ , and  $\gamma$  are all real for a reactive structure, and the matrix determinant is of unit value. The insertion loss  $L$ , which is defined as the ratio of the power transmitted into a matched load from a direct connection to the generator to that obtained with the four-pole inserted, is related to the elements of the transfer matrix by

$$L = 1 + \frac{1}{4}[(A - D)^2 + (\beta - \gamma)^2]. \quad (2)$$

The input impedance to side 1, with a unit normalized terminating impedance, is given by

$$Z = \frac{A + i\beta}{i\gamma + D}. \quad (3)$$

It is through (3) that synthesis will eventually be performed, since it gives a simply ordered array of the matrix elements.

Four-pole behavior with the insertion of frequency invariant quarter and half-wavelength transmission lines will be of interest in various aspects of this study. The half-wavelength line is an all-pass 180 degrees phase shift network and is employed as an identity operation with respect to insertion loss when employed in cascade. A simultaneous application of quarter wave lines as cascades before and after a four-pole interchanges diagonal terms in the transfer matrix. This transformation has the effect of inverting transformers, inverting the relative characteristic impedance of a transmission line, and interchanging lumped series reactances and shunt susceptances. These invariant line lengths are to be distinguished from physical transmission lines, which pass through quarter and half wavelength values as a function of frequency.

### B. Equivalent Representations Involving Ideal Transformers

Weissflock<sup>7</sup> has shown that any reactive four-pole may be represented, at a frequency, as a transformer with associated transmission line lengths. Iris type filters are obtained later from the transformer cavity model through reference to the Weissflock network equivalents, shown in Fig. 3, for lumped series and shunt elements. Symmetric employment of transformers (Fig. 4) furnishes a ready equivalence to the junction of two transmission lines of different characteristic impedance.

<sup>7</sup> A. Weissflock, "Anwendung des transformersatzes über verlustlose vierpolen auf die hinter einander schaltung, von vierpolen," *Hochfreq. Tech. Electr. Akust.*, vol. 61, pp. 19-28; January, 1943.

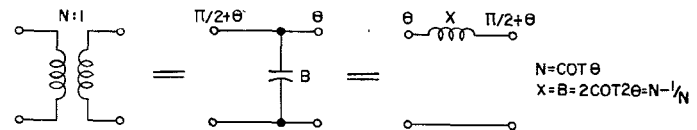

Fig. 3—Some transformer equivalents.

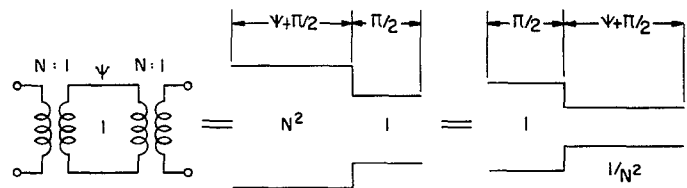

Fig. 4—Transmission line equivalents.

The transformer portion of the Weissflock representation determines the insertion vswr of the four-pole. The transformer ratio, or its reciprocal, is equal to the square root of this vswr.

### III. FILTER EQUIVALENTS

A symmetrically loaded filter structure is illustrated in the transformer cavity representation of Fig. 5. Although symmetrically loaded, the network is electrically unsymmetric to within the addition of a quarter wavelength section. This construction is a direct coupled representation, since adjoining transformers coalesce. A quarter wave coupled construction results from the transformations shown in Fig. 6 which employ invariant half wavelength identity sections and quarter wavelength transformer inverting sections.

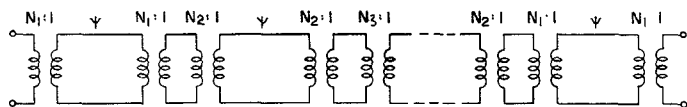

Fig. 5—Symmetric cavity array filter.

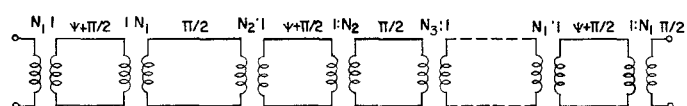

Fig. 6—Quarter wave coupled filter.

Fig. 6 is, at best, an idealized representation, since the coupling sections are of invariant quarter wave nature. The resonant cavity length  $\psi + (\pi/2)$  is, however, permitted a realistic frequency variation, since  $\psi$  itself may undertake any appropriate variation as a function of frequency suitable to the radian length  $\psi + (\pi/2)$ .

The direct coupled structure of Fig. 5, as indicated, is incapable of realizing loss functions having a center-band mismatch. This situation may be overcome by considering the filter structure to be designed to a modified characteristic impedance. This situation, in turn, may be depicted simply by adding a pair of match-

ing transformers at the filter terminals. In practice, these added transformers may be realized by appropriately tapering the transmission line impedance to whatever value may be required at the filter terminals.

It may be demonstrated simply that a transformation of  $N$  to  $1/N$  in these representations produces no effect on insertion loss. We shall, therefore, generally restrict the analysis to  $N > 1$ .

A. Line Type Filters

Fig. 6 leads to the line filter structures shown in Fig. 7(a) and 7(b). These filters are each comprised of an array of sections, all of equal length, but varying in characteristic impedance. The second of these two figures is derived from the former by the inversion properties of the quarter wavelength sections. The structure shown in Fig. 7(b) has been used as a low pass structure, although there generally is no adherence to the requirement that the sections be of equal length. This lapse is permissible for small section lengths, since insertion losses there depend simply on the product of the characteristic impedance and line length, and either may modify the other. This is, however, an approximation valid only for small electrical line lengths and is improper in band-pass constructions.

Fig. 7(b) is an imperfect wideband structure, because of the existence of discontinuity effects. However, the compensation techniques of Section V adequately diminish these effects and this type of filter is employed eventually in wide-band operation. One may, however, directly obtain a coaxial line filter by the use of dielectric beads to effect impedance variations without discontinuity susceptances. The coaxial line, thus, permits a theoretically perfect realization of the filter design.

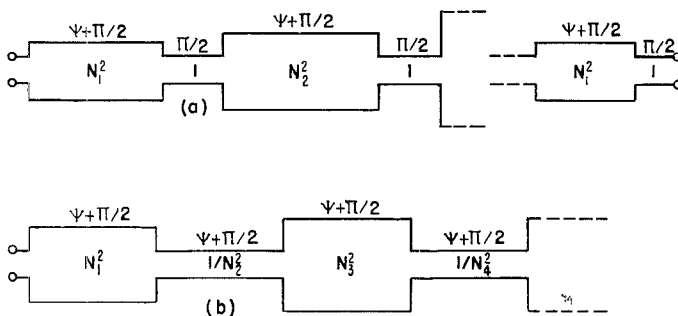

Fig. 7—Quarter wave and direct coupled line filters.

B. Iris Coupled Filters

The direct<sup>8,9</sup> and quarter wave coupled<sup>1,2,10</sup> iris type filters follow directly from Figs. 4–6. A filter comprised

<sup>8</sup> J. Hessel, G. Goubau, and L. R. Battersby, "Microwave filter theory and design," Proc. IRE, vol. 37, pp. 990–1000; September, 1949.

<sup>9</sup> H. J. Riblet, "Synthesis of narrow-band direct-coupled filters," Proc. IRE, vol. 40, pp. 1219–1223; October, 1952.

<sup>10</sup> W. L. Pritchard, "Quarter wave coupled waveguide filters," J. Appl. Phys., vol. 18; October, 1947.

of series reactances is simply related to the susceptance (iris) type. The iris structures are shown in Fig. 8(a) and 8(b) where

$$\theta_n = \frac{1}{2} \text{arc cot } \frac{B_n}{2}$$

$$\alpha_n = \frac{1}{2} \text{arc cot } \frac{B_n}{2}$$

$$B_n = N_n - \frac{1}{N_n}$$

$$B_n' = N_{n-1}N_n - \frac{1}{N_{n-1}N_n}$$

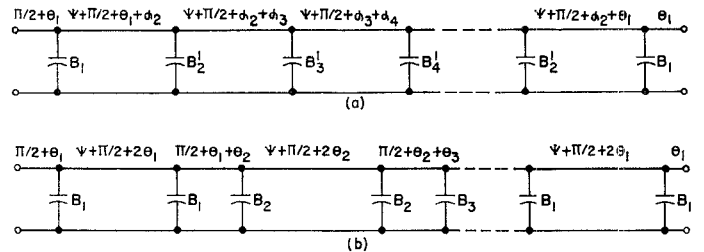

Fig. 8—Direct and quarter wave coupled iris filters.

The iris realizations are frequency sensitive, since the Weissfloch equivalent of the transformer is invariant and the physical elements approximating it are not. Nevertheless, we may expect the direct coupled filter to be the less frequency sensitive realization of the two types.

It will be of interest to remark on the properties of a two-section direct coupled iris filter. The central iris has an insertion vswr which is the square of that of either external iris. Thus, in the high susceptance limit, the central iris has a relative susceptance equal to the square of that of either external iris. In the low susceptance limit, the central iris takes on a susceptance value double that of either external iris. The cavity lengths vary from a half to a quarter wavelength over the same range of susceptance.

C. Narrow-Band Correspondence to Lumped Resonant Elements

The transfer matrix of the elementary transformer cavity of Fig. 1 is given by

$$T_1 = \begin{pmatrix} N^2 \cos \psi & i \sin \psi \\ i \sin \psi & \frac{1}{N^2} \cos \psi \end{pmatrix}, \tag{4}$$

where the subscript on  $T$  indicates the matrix to be that of a single cavity. Narrow band approximation is achieved by placing  $1/N^2$  equal to zero and setting  $\sin \psi$  to unity. Thus, in the neighborhood of  $\psi = \pi/2$

$$T_1 \simeq \begin{pmatrix} -\omega & N^2 \frac{d\psi}{d\omega} \frac{\delta\omega}{\omega} & i \\ & i & 0 \end{pmatrix} = \begin{pmatrix} 0 & i \\ i & 0 \end{pmatrix} \begin{pmatrix} 1 & & & 0 \\ & i \left( \omega N^2 \frac{d\psi}{d\omega} \frac{\delta\omega}{\omega} \right) & & 1 \end{pmatrix}. \quad (5)$$

Eq. (5) suggests a decomposition into a quarter wavelength line and a shunt susceptance

$$\left( \omega N^2 \frac{d\psi}{d\omega} \right) \frac{\delta\omega}{\omega},$$

where the linear frequency variation of the susceptance indicates the neighborhood of resonance.

The susceptance of a shunt resonant network characterized by a doubly loaded value of  $Q$  is given as

$$B = 2Q \frac{\delta\omega}{\omega}.$$

Therefore,

$$N^2 = \frac{2Q}{\omega \left. \frac{d\psi}{d\omega} \right|_{\psi=\pi/2}}. \quad (6)$$

This relationship may be further simplified to

$$N^2 = \frac{Q}{m\pi} \left( \frac{\lambda_0}{\lambda_{g0}} \right)^2, \quad (7)$$

where  $m$  is the number of half wavelengths of the cavity, and where the zero subscript indicates evaluations made at centerband.  $\lambda_0$  is the guide wavelength and  $\lambda$  is that for free space.

Two narrow band equivalents of the cavity are shown in Fig. 9. Cascading the various cavity sections leads to a quarter wave coupled series array of lumped series resonant elements, a quarter wave coupled shunt array of lumped shunt resonant elements, or, finally, a direct coupled alternation of series and shunt elements in a ladder array.

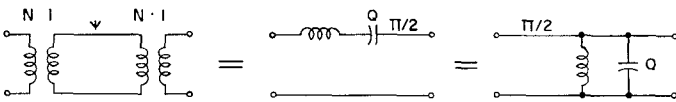

Fig. 9—Narrow band equivalents.

#### IV. DESIGN OF QUARTER WAVE TRANSFORMERS

We may again utilize the symmetric application of transformers to a transmission line, but in a different fashion from that used earlier. A real impedance mismatch may be characterized by a matched load preceded by a transformer. We may achieve this represen-

tation by an appropriate construction in which the transformer used to mismatch the load is part of a filter array.

Consider the direct coupled filter of Fig. 10(a), opposite, where the additive transformers  $N_0$  are included for completeness in representing the centerband mismatch case. Let us "purloin" a transformer of  $N:1$  ratio from the last cavity section and rearrange the transformer array retrogressively, so that the transformers associated with any line section are symmetrically arranged. As shown in Fig. 10(b), an eventual accumulation occurs at the generator end of a transformer of value  $\prod_i N_i:N$ . This may be removed, by simply setting the ratio to unity so that

$$\prod_i N_i = N, \quad (8)$$

where the product extends over every transformer of the filter array. If the transformer  $N$  is employed to produce a load of relative resistance  $\rho$ , we have

$$N = \rho^{1/2}. \quad (9)$$

We then have the final configuration of Fig. 10(c).

For that frequency for which  $\psi = \pi$ , the filter of Fig. 10(a) appears as a single transformer of value  $\prod_i N_i$ , so that from (9), and given the polynomial insertion loss

$$L = 1 + R_n^2(\cos \psi), \quad (10)$$

we have,

$$L(1) = 1 + R_n^2(1) = 1 + \frac{(\rho - 1)^2}{4\rho}. \quad (11)$$

It will be shown in the following section, that any even insertion loss function of the form of (10) is realizable as a symmetric cavity array, if  $R_n$  is an  $n$ th degree polynomial. Then, given any even or odd polynomial of  $n$ th degree  $F_n(\cos \psi)$ , we obtain the following general form of insertion loss of the quarter wave section matching transformer for the specified real termination impedance  $\rho$ :

$$L = 1 + \frac{(\rho - 1)^2}{4\rho} \left[ \frac{F_n(\cos \psi)}{F_n(1)} \right]^2. \quad (12)$$

### V. A GENERAL FILTER SYNTHESIS AND ITS REALIZATION

#### A. Synthesis

Synthesis of a filter, to a prescribed even insertion loss of polynomial nature of the form of (10), is accomplished by a modification of the Darlington<sup>11</sup> synthesis procedure, which takes the distributed nature of the line lengths into account.

<sup>11</sup> S. Darlington, "Synthesis of reactance 4-poles which produce prescribed insertion loss characteristics," *J. Math. Phys.*, vol. 18, pp. 257-353; September, 1939.

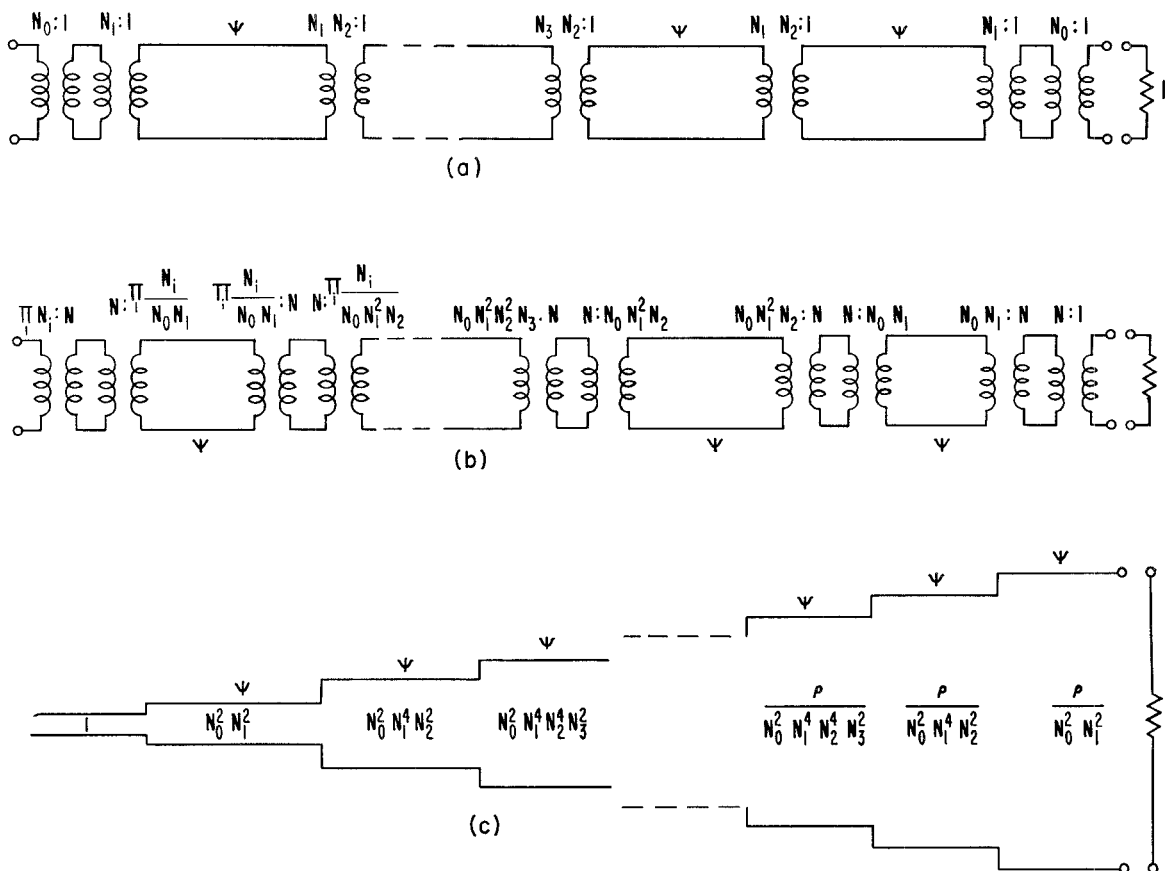

Fig. 10—Development of the quarter wave transformer.

Define:

$$u = \cos \psi,$$

$$p = -iu.$$

We now employ a “radical factoring” identity given as

$$(p - p_i)(p + p_i)(p - p_i^*)(p + p_i^*)$$

$$= |1 + p_i^2|^2 (p - \zeta_i \sqrt{1 + p_i^2})(p + \zeta_i \sqrt{1 + p_i^2})(p - \zeta_i^* \sqrt{1 + p_i^2})$$

$$(p + \zeta_i^* \sqrt{1 + p_i^2}) \quad (13a)$$

where

$$\zeta_i^2 = \frac{p_i^2}{1 + p_i^2}. \quad (13b)$$

The special case in which  $p_j$  is real produces the modified identity

$$(p - p_i)(p + p_i)$$

$$= |1 + p_i^2| (p - \zeta_i \sqrt{1 + p_i^2})(p + \zeta_i \sqrt{1 + p_i^2}). \quad (14)$$

The quantities  $p_j$  are the roots of an expression that will be discussed shortly. These roots appear symmetrically about the origin in the complex plane, this array stemming from the even polynomial loss character of the filter. The left-hand side of (13) is just the de-

composition that occurs in the Darlington theory. This decomposition is inadequate to describe transmission line filters which, as may be seen from the matrix expression of (4), require the existence of terms in  $\sin \psi$  as well as  $\cos \psi$ . The radical expressions of the right of (13) are just the sine of  $\psi$ , giving the motivation to this factoring.

The method of synthesis may be described now. Let it be required, to obtain the following even insertion loss function, that

$$L = 1 + R_n^2(u), \quad (10)$$

where  $R_n(u)$  is an  $n$ th degree polynomial. It is appropriately odd or even from the requirement that  $R_n^2(u) = R_n^2(-u)$ . The insertion loss may also be described in terms of a reflection factor  $k(u)$  and we have the relationship

$$|k(u)|^2 = k(u)k^*(u) = \frac{R_n^2(u)}{1 + R_n^2(u)}. \quad (15)$$

Employing (8), we may deduce the result

$$1 + R_n^2(u)$$

$$= [X(u) + i\sqrt{1 - u^2}Y(u)][X(u) - i\sqrt{1 - u^2}Y(u)], \quad (16)$$

which is obtained by separating the quantities  $\zeta_j$  into the left and right hand planes, respectively.  $X(u)$  is an  $n$ th degree polynomial in  $u$ , and  $Y(u)$  is of one degree less; both have even squares in  $u$ . A sufficient solution for  $k(u)$  is given by

$$k(u) = \frac{R_n(u)}{X(u) + i\sqrt{1-u^2}Y(u)}. \quad (16)$$

Discarding the arguments, we have the input impedance function

$$Z = \frac{1+k}{1-k} = \frac{(X+R_n) + i\sqrt{1-u^2}Y}{i\sqrt{1-u^2}Y + (X-R_n)}. \quad (17)$$

The total transfer matrix, subject to necessary conditions, is obtained through inspection of (3), namely

$$T_n = \begin{pmatrix} X+R_n & i\sqrt{1-u^2}Y \\ i\sqrt{1-u^2}Y & X-R_n \end{pmatrix}. \quad (18)$$

It may now be shown that  $T_n$  satisfies certain necessary conditions aside from satisfying (2). From (16)

$$|X + i\sqrt{1-u^2}Y|^2 = X^2 + (1-u^2)Y^2 = 1 + R_n^2. \quad (19)$$

$T_n$  is thus seen to possess a unit determinant. Two other requirements imposed by the transformer form of representation are satisfied. They are: 1) the off diagonal terms are equal; and 2) the off diagonal terms possess the proper radical factors.

The major diagonal terms of  $T_n$  are even or odd polynomials and of  $n$ th degree.  $T_n$  may be decomposed by a "chipping away" procedure, where pairs of equal cavity sections are detached simultaneously from opposite sides of the filter, such that each element of the residual matrix is decreased by two degrees in  $u$ . Let  $T_1$  be the leading transformer cavity in the array of  $T_n$ ; then

$$T_{n-2} = T_1^{-1}T_nT_1^{-1}, \quad (20)$$

where

$$T_1^{-1} = \begin{pmatrix} \frac{1}{N_1^2}u & -i\sqrt{1-u^2} \\ -i\sqrt{1-u^2} & N_1^2u \end{pmatrix}. \quad (21)$$

We thus obtain the recurrence

$$T_{n-2k} = T_k^{-1}T_{k-1}^{-1} \cdots T_2^{-1}T_1^{-1}T_nT_1^{-1} \cdots T_{k-1}^{-1}T_k^{-1}. \quad (22)$$

Let

$$T_{n-2k} = \begin{pmatrix} \alpha_k & i\sqrt{1-u^2}\beta_k \\ i\sqrt{1-u^2}\beta_k & \delta_k \end{pmatrix}, \quad (23)$$

where

$$\begin{aligned} \alpha_k &= f_{n-2k}u^{n-2k} + f_{n-2k-2}u^{n-2k-2} + \cdots \\ \beta_k &= g_{n-2k-1}u^{n-2k-1} + g_{n-2k-3}u^{n-2k-3} + \cdots \\ \delta_k &= h_{n-2k}u^{n-2k} + h_{n-2k-2}u^{n-2k-2} + \cdots, \end{aligned}$$

and where  $f$ ,  $g$ , and  $h$  are constants.

It may be shown that a choice of

$$N_{k+1}^2 = \frac{f_{n-2k}}{g_{n-2k-1}} = \frac{g_{n-2k-1}}{h_{n-2k}} = \sqrt{\frac{f_{n-2k}}{h_{n-2k}}} \quad (24)$$

leads to a satisfactory determination of the transformer value, in that  $T_{n-2k-2}$  is reduced to proper degree. The structure may thus be appropriately reduced, eventually leading, at most, to the residue of a single transformer. This residue occurs only in the case of a filter having an even number of sections, since  $R_n^2(0) \neq 0$ .

As stated earlier, the centerband mismatch may be equally well accounted for with the transformer residue occurring not at the center of the structure, but being formed instead, equivalently, as two transformers applied equally to the filter terminals. Considering the quarter wave asymmetry inherent in the filter representation, these transformers act symmetrically to modify the filter characteristic impedance. Fig. 11 shows the manner of extraction of the transformer pair. It may be determined that

$$N_0 = [X(0) + R_n(0)]^{1/2}. \quad (25)$$

It may be shown, in general, that any admissible function  $R_n(u)$ , meeting the requirements stated in this paper, always leads to realizable filter structures.<sup>12</sup>

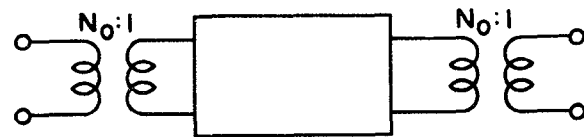

Fig. 11—Extraction of transformers causing centerband mismatch.

### B. Structural Realization

The line type filter of Fig. 7(b) shows the greatest potential for wideband realization. The difficulty related to such realization, through the existence of discontinuity susceptances, may be mitigated by forming the individual sections into elementary, maximally flat two-section filters.

<sup>12</sup> Corresponding to every admissible polynomial  $R_n$  there is a unique transformer array  $N_i^2$ , based on the above method of development. The filter is unrealizable, if one or more values of  $N_i^2$  goes negative. For this to occur, there must first be a region of  $R_n$  where some of the transformer values either tend toward zero or infinity. In either event, one of the elements in the matrix of (21) becomes singular, and this may be shown to contradict the finite nature of the loss function hypothesized for the filter.

Consider an individual section of a compensated structure, shown in Fig. 12, in which a value of susceptance has been inserted at the center of a line section double to that value occurring at either end. Given small values of the relative susceptance  $b$ , the line section is maximally flat in the neighborhood of a line length  $\theta = \pi$ . Maximal flatness indicates an approximate equivalence to a unit characteristic impedance transmission line with some phase shift alteration. This phase shift effect shows up as a modification of line length which, for capacitive susceptances, takes on the character of a new physical transmission line. Having such susceptances, one requires the following mechanical length for a half wave section of line:

$$l = \lambda_{g0} \left( \frac{1}{2} - \frac{b(0)}{\pi} \right), \quad (26)$$

where the zeros refer to centerband.

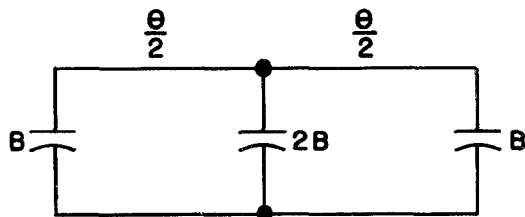

Fig. 12—Susceptance compensation.

The application of (26) is not unique. The susceptances occurring at a discontinuity may be absorbed between the two adjacent line sections in any arbitrary fashion, with susceptive irises possibly added at these discontinuities, to equalize susceptance values. The method adopted for design in this paper is such that each transmission line is made to appear identical to every other on a relative basis. The susceptances are then, in absolute value, divided proportionally to the line admittance at a discontinuity, with whatever positive susceptance required added, to provide equalization to other transmission lines. The justification of such a procedure is described below.

Let every compensated section be characterized by an impedance  $Z'$  and a length  $\theta'$ , both functions of frequency. The ratios of  $Z'$  remain identical with frequency from section to section, and all  $\theta'$  are equal. The internal filter characteristic, therefore, perfectly realizes the design in terms of the quantity  $\theta'$ . Since  $\theta'$  differs from the ideal line length  $\theta$  by second order quantities over the band of interest, the departure of internal characteristics is likewise of second order. Thus, compensation deviations of the equalized filter with equal length sections are not cumulative with respect to the number of sections. A small termination mismatch exists, due to the ratio of  $Z'$  to the actual line impedance. This is guaranteed small over a relatively large band by the choice of the maximally flat sections.

It is of interest to determine the limitations, if any, imposed by the discontinuities on the range of applicability of the line type filter. Given a junction between two rectangular waveguides of the same widths of large height ratios, the entire susceptance normalized to the smaller of the two guides<sup>13</sup> of the order of

$$b \sim \alpha H \ln \alpha,$$

where  $\alpha$  is the ratio of the smaller to the larger height, and  $H$  is the height of the larger guide.  $H$  has an upper limit given by higher mode considerations, and  $b$  has a maximum value with respect to  $\alpha$ . This value is never large, permitting the line type of design, in theory, for narrow as well as large bandwidths.

In the design of a 20 per cent bandwidth maximally flat four-section waveguide filter, a maximum susceptance occurs of value  $b = 0.15$ . Since this is of the order of the largest susceptance to be expected, some numerical data are given in Table I.  $\lambda_{g0}/\lambda_g = 0.846$  gives the 3 db loss point.

TABLE I  
COMPENSATED LINE SECTION

$\lambda_g/\lambda_{g0}$	$\theta$ degrees	$\theta'$ degrees	$Z'$
1	180	180	1
0.85	153	152.2	0.963
0.80	144	143.8	0.955

### C. Typical Design

A test case was computed based on the following specifications:

Guide internal dimensions	2 inches $\times$ 1 inch
Center frequency	5.0 kmcs
3 db bandwidth	20 per cent
Type of characteristic	maximally flat.

The insertion loss function that results is given by

$$1 = 1 + 404 (\cos \psi)^8.$$

The corresponding ideal line section filter is shown in Fig. 13.

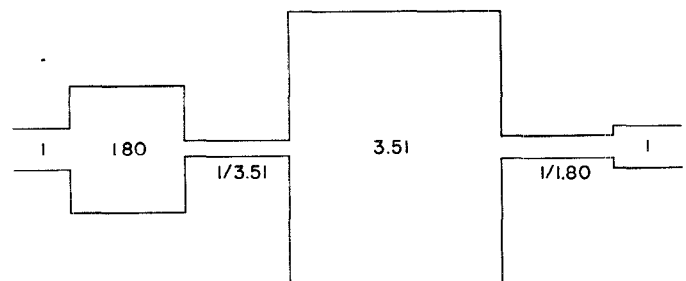

Fig. 13—Uncompensated 20 per cent bandwidth filter.

<sup>13</sup> Marcuvitz, "Waveguide Handbook, Vol. II," Mass. Inst. Tech. Rad. Lab. Series, McGraw-Hill Book Co., Inc., New York, N. Y.; 1951.

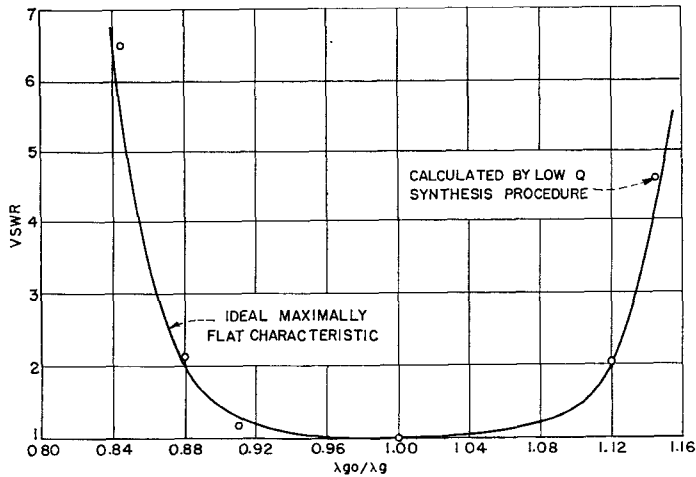

Fig. 14—Filter design employing compensated line type synthesis.

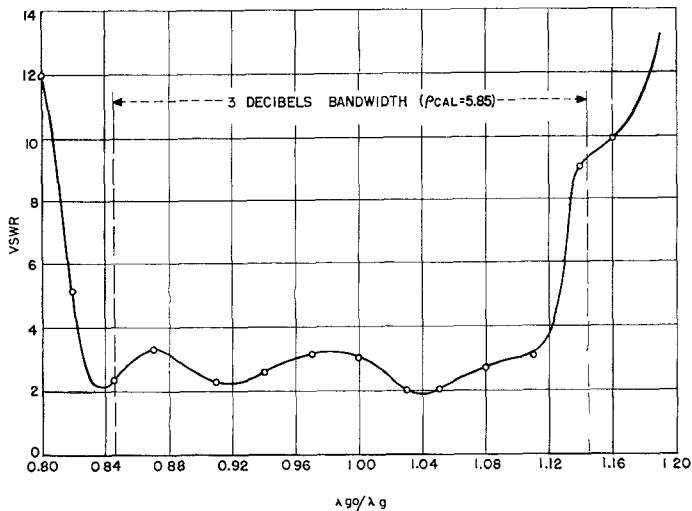

Fig. 15—Line type synthesis with discontinuity compensations omitted.

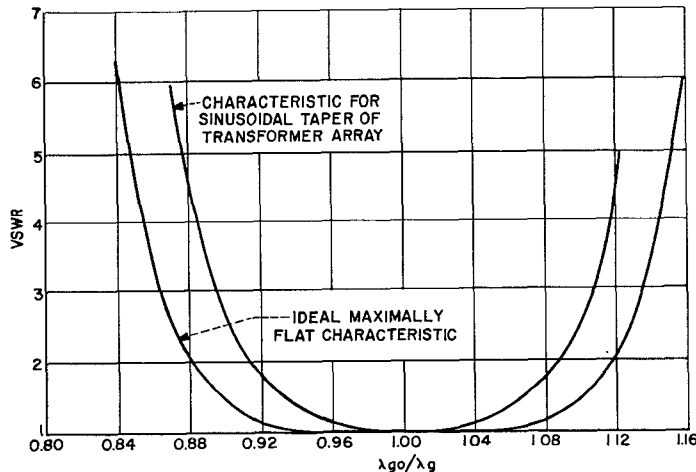

Fig. 16—Effect of ideal narrow-band synthesis application to a 20 per cent bandwidth filter.

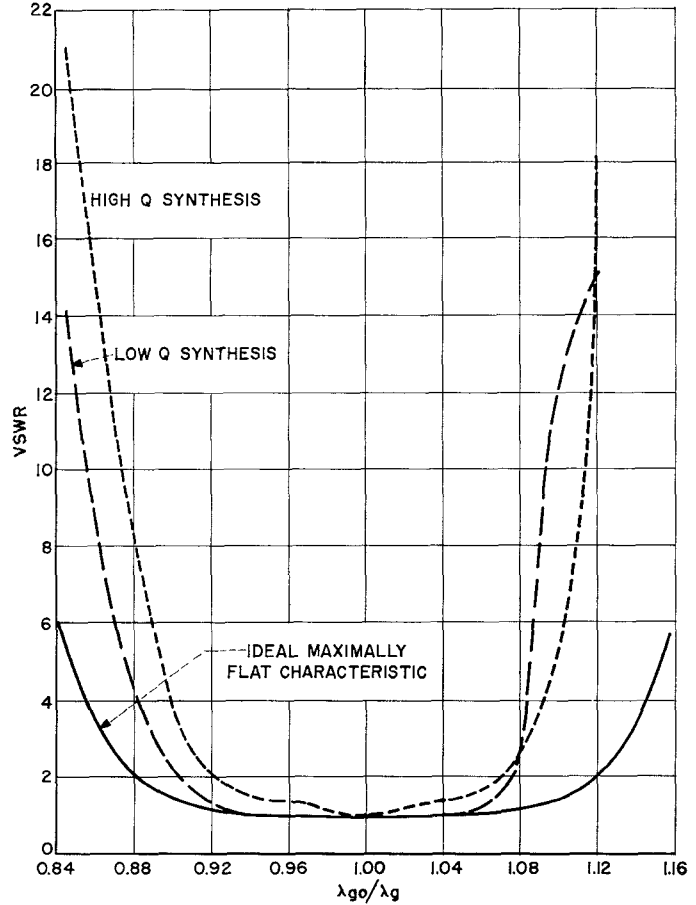

Fig. 17—Effect of use of narrow-band iris equivalents in wide-band filter synthesis.

Figs. 14-17 show the effects of the wide-band synthesis procedure.

Fig. 14 shows the nature of agreement of the voltage standing-wave-ratio characteristics of the synthesized compensated line type filter to the specified curve as a function of frequency. The deteriorating effects of the omission of susceptance compensations are shown by Fig. 15. Fig. 16 shows a comparison of the vswr characteristics of an ideal filter, designed by an unmodified Darlington procedure, to the specified vswr curve. Fig. 17 shows the effects of using an iris type direct coupled filter, designed by either the Darlington or radical factoring procedure.

Only Fig. 14 demonstrates good agreement to the specifications.

ACKNOWLEDGMENT

I should like to thank Dr. A. A. Oliner for his critical review and salient suggestions in the writing of this paper. I am indebted to my sister, Mrs. Ethel Maloy, for her collation of the dissertation manuscript. I also should like to express my appreciation to D. J. LeVine and J. A. Kostriza for their interest in this work.